

ITPA SHORT COURSES



MobiWeb
INFOCENTER

HRDF CLAIMABLE



Facebook
ITPAPenang



WhatsApp
+6016 647 4188



ITPA

INFOTECH PRO ACADEMY
(Center Code: L01951)



CONTACT US NOW

+604 611 7588

info@itpa.my

Working Hours:

9AM - 9:30PM (Mon - Fri)

5-5-37, Persiaran Mahsuri,
Bandar Bayan Lepas,
11900 Bayan Lepas,
Penang, Malaysia.

www.itpa.my

Courses

- 14 Power Tools
- 15 ProfiCAD
- 16 Project Documentation 101
- 17 Report Writing Skills
- 18 Server Hardware
- 19 Shotcut Video Editing
- 20 SOCSO
- 21 Solar Power Project
- 22 SQL Accounting Software Basic
- 23 The Android OS
- 24 Traffic Light Electronic
- 25 Web Design Concept
- 26 Windows 10

Duration

- 1 day
- 2 days
- 3 days
- 1 day
- 2 days
- 3 days
- 3 days
- 2 days
- 3 days
- 2 days
- 2 days
- 2 days

Price

- RM 200
- RM 399
- RM 399
- RM 200
- RM 399
- RM 399
- RM 499
- RM 399
- RM 399
- RM 399
- RM 200
- RM 399
- RM 399





LAPTOP REPAIRING

Laptops evolve all of the time and there are so many variations that if you plan to repair laptops for a living you really need to understand how they work. You need to be able to apply your knowledge to any type of laptop or netbook without constantly referring to tear down guides.

This course will give you the skills to work as a laptop repair technician – perhaps start your own business, add to your existing skill-set, save money by repairing your own laptop or even just learn a great useful new skill.

SYLLABUS

- Laptop Repair Basics
- Business Opportunity
- Laptop Basic Understanding
- System Upgrade
- Dismantle & Assemble
- Basic Laptop Diagnostic
- Laptop Maintenance



INTENDED FOR

ALL PEOPLE WHO USE POWER TOOLS

OPERATORS

SUPERVISORS

MANAGERS

SAFETY PROFESSIONALS

TRADES PEOPLE

Power Tools course explains the uses, selection, safety and care of industrial power tools: power drill, grinder and mini hand drill.

Power tools can be very hazardous in construction and have the potential for causing severe injuries when used improperly. Special attention towards power tool safety is necessary in order to reduce or eliminate these hazards.

This course covers on how to use drill bits, grinder discs and mini hand drill. Practical experience in the selection, inspection and safe use of various types of power tools also will be provided.

POWER TOOLS

Grinder



Mini Hand Drill



Power Hand Drill



The Electrical Basic Course has been designed for school leavers and beginners who are looking to get some basic training and information in the electrical industry to start a career as an electrician or as an electrical installer.

This course is an ideal starting point in your new electrical career. It provides a basic conceptual understanding of basic electrical concepts, including electrical measurements and an understanding of how common electrical components work.

ELECTRICAL BASIC

SYLLABUS

ELECTRICAL WIRE
SIZE, TYPE, COLOR
WIRE GAUGE
RESISTIVITY
SKIN EFFECT
SUPERCONDUCTOR
ELECTRIC POWER TRANSMISSION
POWER PLANT
TRANSFORMER
SINGLE & 3 PHASE ELECTRIC
KWH METER
DISTRIBUTION BOARD
CIRCUIT BREAKER
INDUCTION MOTOR
1 PHASE, 3 PHASE & DC MOTOR



TRAFFIC LIGHT ELECTRONIC

This course is suitable for Electronic Hobby, Primary / Secondary School Students and School Leavers.



This kit is designed to mimic the traffic light.

- 01** After supplying 9V battery cell, it will turn on red LED first.
- 02** The duration of each LED can be controlled by tuning the potentiometer.
- 03** After certain timing, green LED will be lighted up and followed by yellow LED.



www.itpa.my

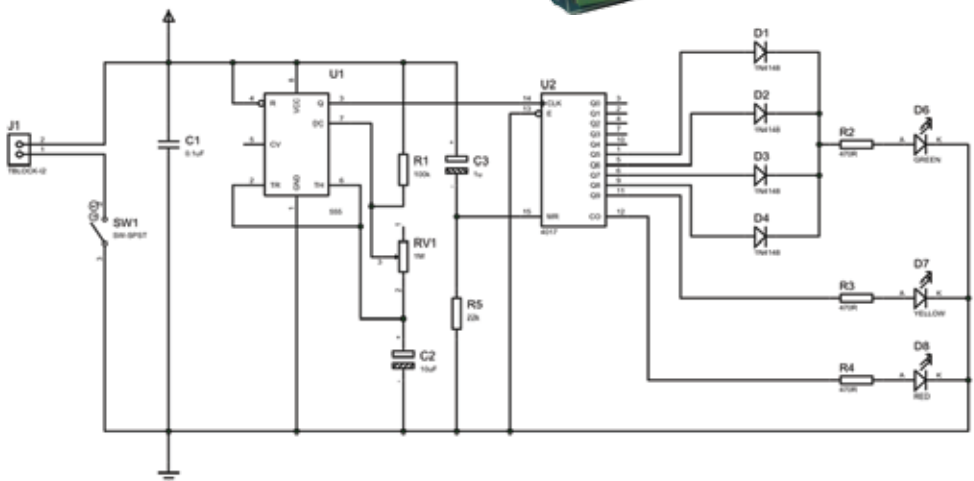

SOLAR POWER PROJECT

This course will be of great interest to homeowners or business owners who are interested in investing solar power and students of science or simply anyone who would like to learn more about renewable energy.

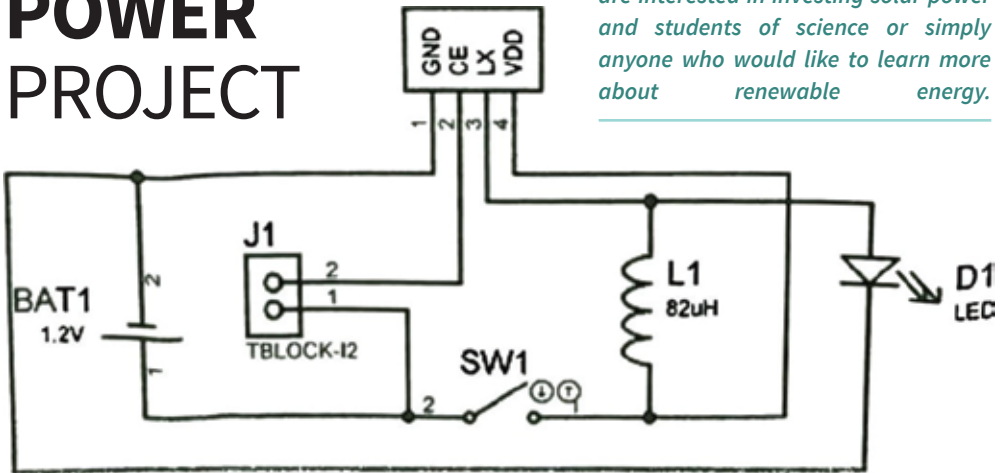

The world today is facing an energy crisis – as long as the earth's climate temperature and sea levels continue to rise, a solution to save our planet must be found. Renewable energy is an important part of this solution and, more particularly, so is solar energy.

The Solar Power Project course is designed to demonstrate the charging system by using solar energy.



01 In a daytime, as sunlight falls on the solar cell, the solar energy is converted into electrical energy and stored in the battery.

02 In the evening, the on board LED will light up automatically by using the power of charged battery.

03 This solar LED kit can be last for about 7 hours after full charged.

OCCUPATIONAL SAFETY & HEALTH

Occupational Safety & Health Act 1994 (OSHA) was gazetted in February 1994 which cover nearly all sectors except person working on board ships and the and the armed forces armed forces. It provides wide coverage-nearly 90% of workforce.

Occupational Safety and Health plays such a pivotal role in the workplace – ensuring that relevant safety and health standards, as well as procedures, are carefully observed to reduce potential occupational hazards.

If you are passionate about playing your part in protecting the lives of hardworking workers and combating the rising rate of occupational accidents, then make further inspections on why Occupational Safety & Health may be the right course for you!



ACT 514

“An Act to make further provisions for securing the safety, health and welfare of persons at work, for protecting others against risks to safety or health in connection with the activities of persons at work, to establish the National Council for Occupational Safety and Health, and for matters connected therewith.”

OBJECTIVES

- ✓ Expose to Malaysia environmental and OSH legislation.
- ✓ Provide guidance on its interpretation and application.
- ✓ Understand the important of environmental and OSH law and take necessary action to ensure it compliance.

SYLLABUS

1. OSHA's Process for Dealing with Accidents, Illness and Worker Complaints
2. Standard Application
3. Fire Safety
4. Environment Ergonomics

The SOCSO Act 1969 is a national insurance scheme for Malaysian employees for employment injury or invalidity

SOCSO

THE SOCIAL SECURITY ORGANISATION

The Social Security Organization (SOCSO) provides social security protection by social insurance including medical and cash benefits, provision of artificial aids and rehabilitation to employees to reduce the sufferings and to provide financial guarantees and protection to the family. It is commonly known in the Malay term as PERKESO or Pertubuhan Keselamatan Sosial.

SOCSO is an organization protects Malaysian employees as accordance with Employees' Social Security Act 1969.

SOCSO has two insurance schemes for its members, the *Employment Injury Scheme* which provides coverage for workplace accidents, and the *Invalidity Scheme* which provides coverage to employees who suffer from invalidity or death due to any cause and not related to their employment.



OBJECTIVES

1. Know the latest revision and compliance requirements of the SOCSO Act.
2. Identify employee's right and obligation.
3. Know standard process to claim and standard process to apply.

REGULATION

CLAIMS

EMPLOYEE'S RIGHT

EMPLOYEES'S OBLIGATION

STANDARD PROCESS TO CLAIM

STANDARD PROCESS TO APPLY

SYLLABUS



This course is suitable for

- ✔ Employers
- ✔ HR Managers
- ✔ HR Executives
- ✔ Payroll Specialists
- ✔ Executives
- ✔ Supervisors
- ✔ Officers

EMPLOYMENT ACT

This course seeks to identify the rights and obligations of both employers and employees. All the relevant legislation related to labour laws will be explained in detail to impart valuable insights on the key principles and practices that are crucial to human resource management in Malaysia including the:

1. *Employment Act 1955*
2. *Industrial Relations Act 1967*

EMPLOYMENT ACT 1955 (EA)

An Act relating to employment

- Module 1 : Introduction**
- Module 2 : Contract of Service**
- Module 3 : Payment of Wages**
- Module 4 : Employment of Women**
- Module 5 : Sexual Harassment (SH)**
- Module 6 : Amendments –
Employment Act 1955 (Act 2012)**



INDUSTRIAL RELATIONS ACT 1967 (IRA)

An Act to promote and maintain industrial harmony and to provide for the regulation of the relations between employers and workmen and their trade unions and the prevention and settlement of any differences or disputes arising from their relationship and generally to deal with trade disputes and matters arising therefrom.

- Module 7 : Introduction**
- Module 8 : Managing Poor Performance**
- Module 9 : Misconduct**
- Module 10 : Stages Of Disciplinary Process**
- Module 11 : Labour Court**
- Module 12 : Dispute Resolution**

Get started editing your own videos with an incredible free video editing software for Windows, Linux or IOS.

SHOTCUT VIDEO EDITING



SYLLABUS

- ▶ ADDING VIDEO CLIPS, AUDIO & IMAGES TO VIDEO
- ▶ USING THE TIMELINE
- ▶ ADDING TRANSITIONS
- ▶ ADDING CAPTIONS OR TITLE SCREENS
- ▶ RECORDING NARRATION
- ▶ EXPORT YOUR VIDEO

Are you looking for an easy to use and powerful video editing software?

This course will teach you how to get started with video editing quickly using the free Shotcut Video Editing software, which rivals some of paid software.

You do not need to settle for video editing software that is expensive, difficult to learn and lack of necessary tools to make professional videos.

Who is this course for:

- 01** Video creators looking for a powerful and easy to use video editing software.
- 02** Video editors who wants a pro level video editing software on a budget.
- 03** Marketing video creators who want to create videos quickly.

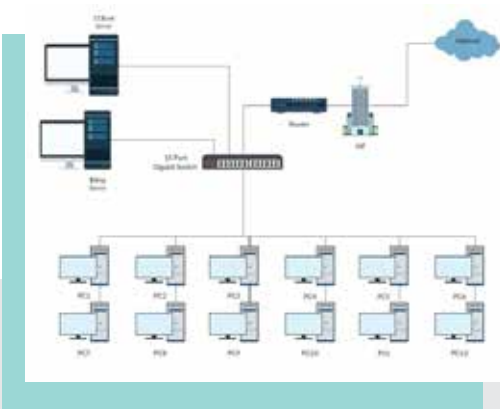

SYLLABUS

- 01 ELECTRICAL & ELECTRONIC DIAGRAMS
- 02 SCHEMATICS
- 03 CONTROL CIRCUIT DIAGRAMS
- 04 PNEUMATICS
- 05 HYDRAULICS
- 06 OTHER TYPES OF TECHNICAL DIAGRAMS

ProfiCAD

for Electrical, Electronic & Server Layout Drawing

ProfiCAD is designed for drawing electrical and electronic charts and diagrams. The schemes can also be used for pneumatics, hydraulics, and other types of technical diagrams.

ProfiCAD comes with a large library of predefined objects and allows you to customize your project in many ways.

This course is useful both for engineers and for students that want to improve their electronics knowledge level.





This PHP & MySQL 101 course will help beginners to learn the basics of PHP (including conditionals, array, string, and functions) and understand how to connect PHP to a MySQL database.

SYLLABUS

INSTALLATION
BASIC PHP
CONDITIONALS
USING ARRAY
STRING MANIPULATION
REGULAR EXPRESSION
REUSING CODE
FUNCTION
OBJECT ORIENTED
CLASS
MYSQL
USE HEIDISQL
PHP + MYSQL
SAVE TO DATABASE

PHP & MySQL 101

PHP is a popular, reliable programming language at the foundation of many data-driven CMS websites such as Wordpress, Joomla and Magento.

PHP is a very versatile web development language that is used to build dynamic web pages by deploying server-side scripting. It offers multiple benefits like advanced features, easy to use and open source nature.

MySQL is a database solution that is extremely powerful, secure and

scalable making it ideal for using with sophisticated websites.

This comprehensive course will help new MySQL users who have little or no previous experience understand relational database management systems.

By investing in this course, you will develop new knowledge and skills to leverage this powerful solution.



This course helps you to build your Android skills and learn best practices.

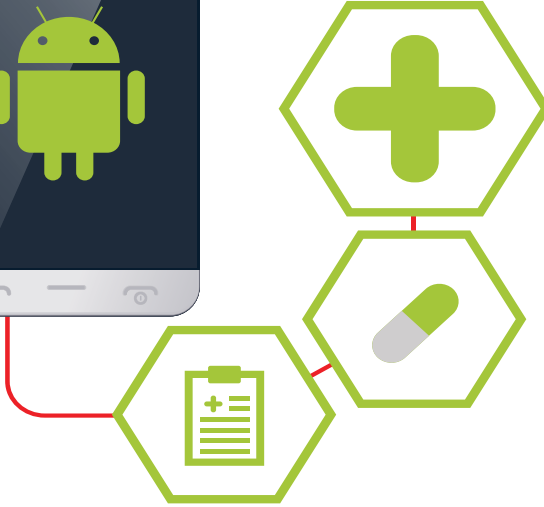

This course is designed for participants who are new to programming and want to learn about Android apps.

You do not need any programming experience to take this course. If you have been using a smartphone to

surf the web and chat with friends, then you are our perfect target participant!

To get the most out of this course, you must bring your enthusiasm for learning and budget time on your calendar to learn with us.

THE ANDROID OS



SYLLABUS

1. PICTURE, VIDEO, MUSIC
2. BACKUP
3. SECURITY & ROOT PERMISSION
4. INTRODUCTION TO ANDROID DEVELOPMENT
5. HARDWARE SPECIFICATION
6. SETUP & CONFIGURE
7. BASIC OPERATIONS
8. EMAIL
9. WEB, SOCIAL NETWORKING
10. MAP

Let's get started with Windows 10 course for IT professionals. This course is designed for students of information technology and IT experts. As an IT Pro, how can you securely enable your organization with Windows 10? Find out all, in this practical and informative course.

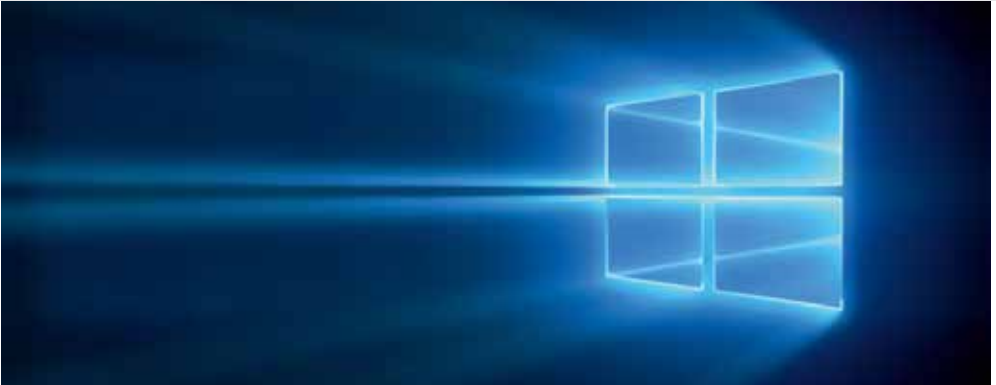

Windows 10

This course is a great opportunity to identify and work with both old and new features of Windows that will constantly continue to develop over the next decade.

The Windows 10 course is designed for both users who know how to operate previous computerised operating systems as well as those that have little to no experience.



SYLLABUS

- Windows 10 Basic Operation**
- Windows User Accounts & Synchronization**
- User Experience**
- Cortana**
- Microsoft Accounts**
- Domain Accounts (Active Directory)**
- Azure Active Directory Accounts**
- Microsoft Edge**
- Windows 10 VPN Configuration**
- IPV6 Support**
- Client Hyper-V**
- Desktop Virtualization Options**
- Application Virtualization**
- User Experience Virtualization**
- Task Manager**
- Resource Monitor**
- Event Viewer**
- Windows Passport**
- Unified Extensible Firmware Interface (UEFI)**
- Data Execution Prevention (DEP)**
- Phishing Protection**
- Deployment Options**
- Disk Management Console**
- Security Policies**

PHOTOSHOP

This course is designed for the absolute beginner, and you will learn Photoshop from the ground up, with **NO PRIOR EXPERIENCE** required!

PHOTOSHOP 101

Introduction
Getting Started
Interface Layout
Palettes
Toolbox
Selection Tools
Alteration Tools
Drawing & Selection Tools
Assisting Tools
Color Boxes & Modes
Basic Image Editing
Cropping
Resizing
Correcting
Sharpening/ Softening
Saving

PHOTOSHOP 102

Summary: Photoshop 1
Make Gaussian Blur Effect
Design a New Photo
Combining 2 Pictures
Cartoon Effect
Making the Nvidia Logo
Blending Photos
Add Color to Black & White Photos
Create a “Nashville” Filter from Instagram
Create a Realistic Broken Glass Effect



A great software for handling pixel images.

Photoshop was made for people who loved to edit and improve their photos. It is an extremely professional photo editing software and a very powerful tool with a lot of flexibility in advanced and detailed adjustments.

Photoshop is the most used software by digital graphic designers,

photographers, web designers and many more.

This course equips you with the skills and tools you will need when you want to create amazing and realistic photo-editing, manipulations and effects.

In addition, you will learn the fundamentals of Photoshop with easy to follow and practical examples.

ADOBE ILLUSTRATOR

HANDS ON

DESIGNING LOGO
 CREATE A VECTOR
 BURGER
 CREATE A FUN
 HIPSTER LOGO DESIGN
 CREATE FLAT
 LONGBOARDS



Adobe Illustrator is the industry-standard vector graphics software, used worldwide by designers of all types who want to create digital graphics, illustrations and typography for all kinds of media such as print, web, interactive, video and mobile.

This Adobe Illustrator course are task-based and focus on real-world uses and challenges individuals face in their day to day work environments.



DRAWING BASIC SHAPES
 DRAWING WITH PENCIL / PEN TOOLS
 USING BRUSHES
 WORKING WITH COLORS & STROKES
 EDITING OBJECTS, LAYERS & GROUPS
 TRANSPARENCY & GRAPHIC STYLES
 TRANSFORMING & MOVING OBJECTS
 BASIC TEXT
 BENDING SHAPES & COLORS
 PHOTOREALISM WITH GRADIENT MESH
 USING SYMBOL TOOLS
 CREATING SPECIAL EFFECTS

INTENDED FOR

Graphic designers or people transitioning into a design job or taking on design responsibilities, who need to use Adobe Illustrator to create illustrations, logos, advertisements or other graphic documents and marketing professionals. They may have little or no experience with Illustrator, although they may already use Adobe InDesign and Adobe Photoshop.

SQL ACCOUNTING SOFTWARE BASIC

If you are an SQL user who wants to make sure your business files are set up correctly for the most efficient use possible, this SQL Accounting Software Basic course is just what you are looking for. Whether you are setting up to get started or are already working with existing company files, you will learn the right way to set up all the relevant accounts.



Login, Setup Company Profile

GST Setting

Maintain GL Account

Maintain Customer

Maintain Supplier

Stock > Maintain Stock Item

Purchase > Purchase Order (PO)

Purchase > Goods Receive (GR)

Purchase > Purchase Invoice (PI)

Sales > Quotation

Sales > Sales Order (SO)

Sales > Delivery Order (DO)

Sales > Invoice

Sales > Cash Sales

Tools > Options > Customer

Sales > Credit Note

WHAT YOU WILL LEARN

Customer Payment

Customer CN

Customer Statement Report

Customer Aging Report

GL > Maintain Opening Balance / Past Invoice

GL > Maintain Stock Value

GL > Bank Recon

GL > Journal Entry

GL > Cash Book Entry

GL > Print P&L Statement

GL > Print Balance Sheet Statement

Sales > Sales Document Listing

GST > New GST Return

Purchase Invoice

Unlock Features in GST Return

Edit Report Format

SYLLABUS

DESIGN PROCESS & EVALUATION

OPTIMIZING THE USER EXPERIENCE

HARDWARE AND SOFTWARE

THE HOMEPAGE

PAGE LAYOUT

NAVIGATION

SCROLLING & PAGING

HEADINGS, TITLES & LABELS

TEXT APPEARANCE

LISTS

GRAPHICS, IMAGES & MULTIMEDIA

WRITING WEB CONTENT

CONTENT ORGANIZATION

SEARCH

USABILITY TESTING

WEB DESIGN CONCEPT



Learning to design a website requires mastering many different skills from organizing the structure of the website, making sure it is easy to use and navigate, to design the graphics and layout of the information.

This Web Design Concept course concentrates on the fundamentals of building a website through understanding of the principles of persuasive website design, resulting in helping you create web design briefs that will help develop online pages that truly add value to your business or brand.

In addition, you will discover that making some simple changes to your web pages can make a huge difference to the number of people who read your content, browse your pages, complete your enquiry forms or make a purchase.

REPORT WRITING SKILLS

Who is it for?

Anybody who writes reports of any kind - from board reports to annual reports.

What level is it for?

From beginners to senior professionals.

If your role involves written communication or you are simply looking to develop your professional writing skills, this is a valuable course for you!

This course has been developed to assist delegates to grasp the essential components of various types of reports and their formats.

High quality reports often form the basis of sound decision making within an organisation.

This Report Writing Skills course takes you through every stage from planning and structuring through to writing and presenting, and by the end of the day you will be a much more confident report writer.



SYLLABUS

DEVELOPING WRITING STYLES
 REPORT REQUIREMENTS
 RESEARCHING
 REPORT PLANNING
 MIND MAP
 POLISHING
 REPORT FORMAT
 ISO REPORT REQUIREMENT
 ISO REPORT FORM SAMPLE



This course is perfect for:

1. *Project Managers*
2. *Team Members*
3. *Senior Managers*
4. *Project Leaders*
5. *Functional Managers*
6. *Information Technology Professionals*

and anyone who is directly involved with projects in almost every industry to certify your knowledge and experience.

Documentation must lay the foundation for quality, traceability and history for both the individual document and for the entire project documentation. It is also extremely important that the documentation is well arranged, easy to read, and adequate.

PROJECT DOCUMENTATION 101

SYLLABUS

- ✓ WORK BREAKDOWN STRUCTURE
- ✓ TIMELINE
- ✓ WORK, PROJECT SCHEDULE
- ✓ JOB CHECKLIST
- ✓ JOB EXECUTION DETAILS
- ✓ GANTT CHART
- ✓ COMPUTER NETWORK
- ✓ DIAGRAM INTERPRETATION
- ✓ DELEGATION
- ✓ MONITORING
- ✓ SUPERVISION
- ✓ COORDINATING
- ✓ USER ACCEPTANCE TEST
- ✓ REPORT FORMAT
- ✓ REPORT CONTENT
- ✓ REPORT SUBMISSION PROCEDURES
- ✓ RECORDING PROCEDURE
- ✓ REPORT WRITING SKILLS



HARDWARE

This course will guide you on how to handle POS System hardware such as barcode scanner, receipt printer, cash drawer, cash drawer trigger, LED display, weighing scale and customer display.



**Barcode
Scanner**



**Receipt
Printer**

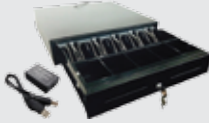

**Cash Drawer
+ USB Trigger**



**Customer
Display**



**Weighing
Scale**



SOFTWARE

Learn about POS System software for:



**Retail
Store**



Membership



Inventory



**Food &
Beverage**



**Queue
Manager**



**Car
Workshop**



**Optical
Store**



**Accounting
Integration**

POS SYSTEM & COMPUTER ACCESSORIES



In this course, you will learn on how a POS System keeps a shared storage of information and a shared access to a database.

DATABASE SERVER VIA MULTI COUNTER POS SYSTEM



SYLLABUS

**HARDWARE SETUP
DIAGRAM**

**MICROSOFT SQL
SERVER INSTALLATION**

**POS CLIENT SERVER
INSTALLATION**

**CONFIGURE BMO POS
TASK SCHEDULER SETUP**

RESTORE BACKUP





SERVER HARDWARE

This course is perfect for beginners with little knowledge of server hardware, through developers, DBAs, managers, and other IT professionals who need to understand how to successfully evaluate and provision new servers.



WHAT YOU WILL LEARN

- 01 **Server Maintenance Tools**
- 02 **Server Racks**
- 03 **UPS**
- 04 **Server Light Status Indicator**
- 05 **Server Room Environment**
- 06 **Server Backup Option**
- 07 **System Logs**
- 08 **Server Virus / Worm**
- 09 **Firewall**
- 10 **Tower Servers**
- 11 **Rack Servers**
- 12 **Blade Servers**
- 13 **Server Specification**
- 14 **Server Hardware Information**
- 15 **Server Warranty Information**
- 16 **Server Contract Maintenance**
- 17 **Server Security Procedure**

Use Calc as the spreadsheet program you have always needed. Newcomers find it intuitive and easy to learn, while professional data miners appreciate the comprehensive range of advanced functions. Built-in wizards guide you through choosing and using an advanced features.

LIBREOFFICE CALC AS MICROSOFT EXCEL ALTERNATIVE



Working with Columns, Rows & Sheets

AutoFormat of Cells & Sheets

Entering, Editing & Formatting Data

Using Conditional Formatting

Sorting, Hiding & Showing Data

Creating Charts & Graphs

Formatting and Editing Charts & Graphs

Using Styles, Templates & Graphics

Adding Graphics & Modifying Images

Positioning, Resizing Arranging Images

SYLLABUS



Printing, Exporting & E-Mailing

Exporting to PDF & to Other Formats

Using Formulas & Functions

Using Pivot Tables, the Pivot Table Dialog

Working with the Results of the Pivot Table

Data Analysis, Consolidating Data

Adding Comments & Reviewing Changes

Merging and Comparing Documents

Calc Macros & Using the Macro Recorder

LIBREOFFICE WRITER AS MICROSOFT OFFICE WORD ALTERNATIVE

Discover the powerful LibreOffice Writer that has given back the control to the user. With an array of features that can help you be more productive and efficient in creating wonderful and professional looking document.

SYLLABUS

- 01 Working with Text
- 02 Creating Numbered / Bulleted Lists
- 03 Using Footnotes & Endnotes
- 04 Using Word Completion
- 05 Tracking
- 06 Formatting
- 07 Setup
- 08 Exporting to PDF
- 09 Working with Style
- 10 Defining a Hierarchy of Headings
- 11 Advanced Form Customization
- 12 Working With Images
- 13 Working With Tables
- 14 Working With Templates
- 15 Using Mail Merge
- 16 Tables of Contents
- 17 Working with Master Documents
- 18 Cross-referencing between Sub-Documents
- 19 Anchoring Pictures to a Page
- 20 Working with Fields
- 21 Creating a Simple Form



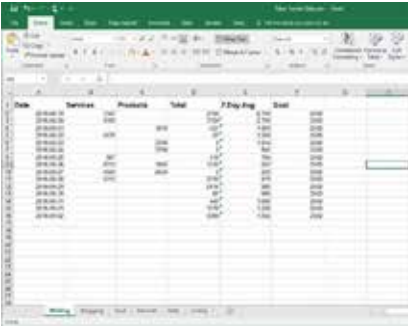

Microsoft Excel is the most commonly used spreadsheet application. Learning Microsoft Excel is an investment in both your personal and professional life.

MICROSOFT EXCEL

Microsoft Excel makes it easy to monitor financial performance, such as business profit or loss, calculate payments on large purchases, plan a budget, or stay organized with checklists.

When employees know how to use Microsoft Excel, it improves their efficiency in the workplace. Employees who know how to create detailed worksheets, invoices, charts, and complex formulas achieve professional results in a fraction of the time.

What you will learn

- CONVERT, SORT, FILTER AND MANAGE LISTS
- CREATE AND MODIFY CHARTS
- INSERT AND MODIFY ILLUSTRATIONS IN A WORKSHEET
- LEARN TO USE CONDITIONAL FORMATTING AND STYLES
- LEARN TO USE FORMULAS AND FUNCTIONS



MICROSOFT WORD

Microsoft Word is a word processing system that can be utilized for both business and personal use.



SYLLABUS

GETTING STARTED WITH WORD
ADDING TABLES
CONTROLLING PAGE APPEARANCE
CUSTOMIZING THE WORD ENVIRONMENT
EDITING A DOCUMENT
FORMATTING TEXT AND PARAGRAPHS
INSERTING GRAPHIC OBJECTS
MANAGING LISTS
PROOFING A DOCUMENT

Microsoft Word short course will help you develop or improve your Microsoft Word skills so that you are able to make the most of this industry standard application.

Who should attend

Administrative Assistants

Office Administrators

Personnel Managers

Secretaries or Clerks



ITPA

INFOTECH PRO ACADEMY



Facebook
ITPAPenang



WhatsApp
+6016 647 4188

5-5-37,
Persiaran Mahsuri,
Bandar Bayan Lepas,
11900 Bayan Lepas,
Penang, Malaysia.

www.itpa.my

CONTACT US NOW

+604 611 7588
info@itpa.my

Working Hours:
9AM - 9:30PM (Mon - Fri)

